

DESIGN AND ANALYSIS OF AUTOMATIC PNEUMATIC RECIPROCATING WATER PUMPING SYSTEM

V. Ramu, K. Vishnu Vardhan, Dolu Swathi, Md. Jameel Ur Rahman, Mr. B. Tejavardhan

Dept. of Mechanical Engineering, SVITS, Mahbubnagar, Telangana, India.

Abstract: *Reciprocating pumps are those in which the oscillating motion of pistons, plungers or membranes causes a fluid to move. In this respect an attempt has been made to increase the discharge by making some modifications in the single-acting pump with the same input power. It has been placed vertically and adjacently to the main cylinder. In our project, Single Acting Multi Cylinder Pump is of positive displacement pump. Due to high precision work involving lower in cost, these pumps are widely manufactured by most of the industries. This piston is reciprocated with the help of a scotch yoke mechanism. This is rotated by the motor. The piston reciprocated does the pumping action. The water in the tank at normal pressure is delivered to a high pressure after pumping. This high-pressure water is utilized for various purposes like gardening, cooling water circulation etc. Scotch yoke mechanism is used first in engines as it can produce high torque. It is also used in conventional machining purposes. The models and drawings are to be made in CAD software like CATIA V5 and for the determination of forces, and the fluid flow analysis of single-acting reciprocating pumps has been performed in Ansys. The various parameters such as mass flow rate of fluid flow, velocity of the fluid flow, volume of the fluid flow and force of the fluid flow have been considered in this paper. These parameters have been studied for cylinder in an outlet to determine the performance of the pump. The results show that, using the same input power used for the single-acting reciprocating pump, the total discharge of fluid of the pump has been increased.*

INTRODUCTION

A responding pump is a class of positive-relocation pumps which incorporates the cylinder pump, plunger pump and stomach pump. At the point when all around kept up, responding pumps will keep going for a considerable length of time or even decades; in any case, left immaculate, they can experience thorough wear and tear. Usually utilized where a moderately little amount of fluid is to be taken care of

and where conveyance weight is very vast. In responding pumps, the chamber in which the fluid is caught, is a stationary barrel that contains the cylinder or plunger.

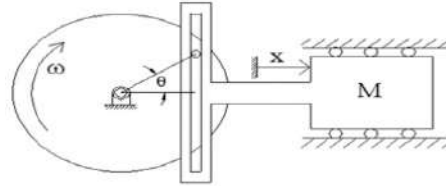

In our task, Double Acting Multi Cylinder Pump is of positive dislodging pump. Because of high accuracy work including lower in cost, these pumps are not generally produced by a large portion of the ventures. This cylinder is responded with the assistance of a scotch burden component. This is turned by the engine. The cylinder responded does the pumping activity. The water in the tank at typical weight is conveyed to a high weight in the wake of pumping. This high weight water is used for different purposes like planting, cooling water dissemination and so forth. Scotch burden system is utilized first in motors as it can create high torque. It is additionally utilized as a part of traditional machining purposes. Here we utilize it for directing water as we require high torque.

1.1 Classification of Reciprocating Pump

By wellspring of work

- Simple hand-worked responding pump
- Power-worked profound well responding pump
- Single-acting responding pump
- Double-acting responding pump
- Triple-acting responding pump

1.2 Components of Multi Acting Reciprocating Pumps

Multi Acting Reciprocating Pumps In industry, responding pumps are of numerous sizes and plans. Their activity is like the bike direct depicted previously. A mechanical responding pump is developed of metal and has the accompanying principle parts:

- **The cylinder**

The cylinder comprises of a metal drive bar associated with the cylinder head which is situated inside the chamber. The cylinder head is fitted with cylinder rings to give a seal against the barrel lining and limit interior spillage. The opposite end of the drive pole stretches out to the outside of the barrel and is associated with the driver. (In the days of yore of cylinder pumps, the driver used to be (and still is at times), high weight steam which was nourished to a drive chamber by an arrangement of valves in a steam chest). Present day businesses by and large utilize high power electric engines, linkages and adapting to change over pivoting movement into a responding activity. In a solitary acting pump, the regressive stroke of the cylinder causes a suction which pulls in fluid through the gulf valve. (A similar suction activity keeps the release valve shut). On the forward stroke, the expansion in weight produced by the cylinder, shuts the gulf valve and opens the release valve. The fluid is dislodged into the release framework. The spill out of a responding pump is uneven or throbbing. This can be unwanted in a few applications. Stream can be smoothed out, however we will examine this somewhat later. Like the turning pumps, in light of the fact that the activity is certain uprooting, a cylinder pump can create high weight and in this way should never be worked against a shut release framework valve except if it is fitted with a security alleviation framework keeping in mind the end goal to counteract harm to the pump as well as the driver and additionally other downstream gear.

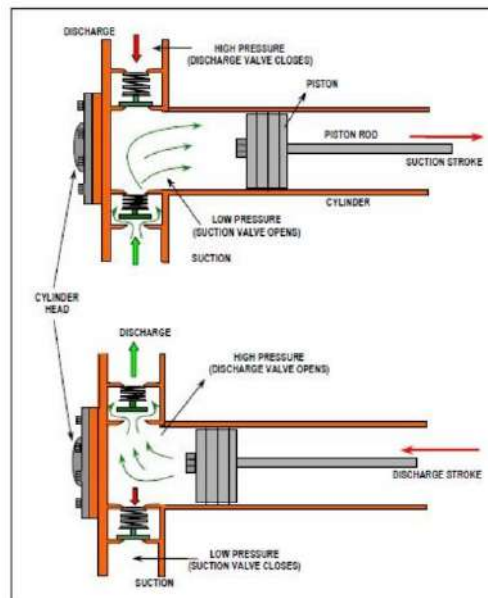

- **The chamber**

This is a metal tube-formed packaging (or body), which is by and large fitted with a metal covering called a 'chamber liner'. The liner is replaceable when it ends up worn and wasteful. The barrel is likewise fitted with suction and release ports which contain extraordinary spring stacked valves to enable fluid to stream one way just - like check valves.

- **Cylinder barrel**

The fundamental capacity of barrel body is to hold chamber weight. The chamber barrel is generally produced using a consistent tube. The chamber barrel is ground and additionally sharpened inside with a run of the mill surface complete of 4 to 16 miniaturized scale inch. Ordinarily circle pressure is ascertained to upgrade the barrel measure. The cylinder responds in the chamber.

- **Cylinder base or top**

The primary capacity of the top is to encase the weight chamber toward one side. The top is associated with the body by methods for welding, threading, jolts, or tie pole. Tops additionally execute as chamber mounting segments [cap rib, top trunnion, top clevis]. Top size is resolved in view of the twisting pressure. A static seal/O-ring is utilized as a part of amongst top and barrel (with the exception of welded development).

- **Piston bar**

The cylinder bar is a hard chromed bit of chilly moved steel which connects to the cylinder and stretches out from the barrel through the bar end head. In twofold pole end chambers, the actuator has a bar reaching out from the two sides of the cylinder and out the two finishes of the barrel. The cylinder bar interfaces the water driven actuator to the machine segment taking every necessary step. This association can be as a machine string or a mounting connection.

- **Seal organ**

The barrel head is fitted with seals to keep the pressurized oil from spilling past the interface between the bar and the head. This zone is known as the seal organ. The benefit of a seal organ is simple expulsion and seal substitution. The seal organ contains an essential seal, an auxiliary seal, and cradle seal, bearing components, wiper, scrubber and static seal. At times, particularly in little water powered chambers, the bar organ and the bearing components are produced using a solitary vital machined part.

LITERATURE SURVEY

The different research works endeavored in the territory of vitality protection and particularly in the region of pneumatic frameworks have been alluded and talked about here. The articles from diaries, magazines, books, particular reports and web sources have been gathered, audited and exhibited in the accompanying areas.

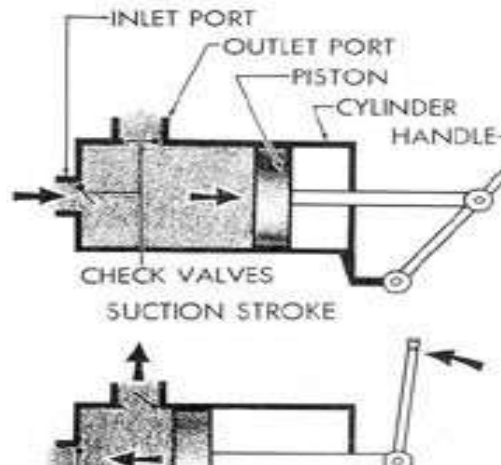

2.1. Detail History

Costagliola at M.J.T. in 1950 created the principal beneficial numerical model of a responding blower and its valves. The examination of valve progression was the essential concern. Comparing trial work was directed with a 3 in bore x 4 in stroke single barrel air blower, fitted with flexing reed "quill" type valves, in the speed go 900-1800 remind. The arrangement of the non-direct differential conditions by graphical strategies was excessively repetitive for the model, making it impossible to be of enthusiasm as a mechanical outline device. Numerous hypothetical weight and valve uprooting graphs were computed, and despite the fact that these were not demonstrated superimposed on test outlines, it was guaranteed that the model was "basically right".

Broad utilization of advanced PCs has enabled later specialists to settle the conditions quickly and has enabled the fundamental model to be refined and expanded. Practically every one of the models now in presence metal construct to some degree in light of the pioneer investigation by Costagliola.

Maintain of the University of New South Wales in 1967 concentrated the conduct of a ring-plate suction valve in one chamber (5 in bore x 4 in stroke) of an eight barrel twofold V compose air blower. Oscillograms of valve uprooting were contrasted and those anticipated by a diagnostic model like Costagliola's nevertheless reached out to represent warm exchange and valve damping. Maintain estimated the coefficient of compensation of the ring plate valves by utilizing a rapid photography strategy. Maintain utilized the model to analyze the impact of changes in different dimensionless lumped parameters on blower execution criteria, specifically their impact on valve affect speed. From Test 719 it could be asserted that the relationship amongst's expository and exploratory outcomes was great. Be that as it may, the valve displacement chart when shudder was available, as in Test 723, demonstrated that this model would be truly in mistake if used to foresee the purpose of conclusive conclusion of the suction valve, affect on the valve seat, or "pass up" misfortune. For this situation the test outline was the more tenable, proposing blunders in the mind boggling PC program or mistakes in the estimations of observational coefficients utilized.

Troversari and Lacitignola in Italy in 1970 developed a model in light of those by Costagliola and Maclaren and Kerr. Changes were mode to represent damping because of the pneumatic sort of valve stop utilized with the multi-ring plate valves. As in many models, release, drag and damping coefficients were accepted to have consistent qualities. Arrangement was likewise made for mimicking delay in valve opening because of oil suction impacts. Thinks about explanatory and exploratory records for a release valve mounted at the internal end of a twofold acting barrel. The weight throbs inside the chamber were very little. This valve when it neglected to achieve its allowed lift and that extreme valve shudder and comparing expansive weight changes resulted. This flimsy circumstance makes an extreme trial of a model and the connection between's logically anticipated and test comes about gives off an impression of being great. The record of a suction valve for the inward end of the twofold acting chamber when late valve conclusion happened. The calculation for a release valve when opening was thought to be postponed by 15 wrench point degrees. Subsequently the valve affect speed at the prevent expanded from $1 \cdot 42$ m/s to 4.98 m/s. (Such a postponement is probably not going to be expected just to oil suction: the rate of increment of weight distinction over a release valve is large to the point that oil suction ought not defer release valve opening by this sum.)

The logical calculation of valve dislodging finished at cylinder inversion. In the arrangement of occasions in the cycle illustrated, the conduct of one valve as it influences the beginning of opening of

the other valve is represented. No doubt the model of Traverse and Lactignola was not adequately total to represent such valve connection. Succession of occasions through an entire cycle. The model incorporated a straightforward reenactment of bay and release pipe work. The suction and release valves examined were multi-finger reeds set circumferentially cycle a barrel, 160 mm bore x 110 mm stroke. In spite of the fact that correlation was made amongst logical and trial records while pumping R22, Fig. 6, demonstrates the examination while directing air at two blower speeds. The expanded shutter of the suction valve at the lower speed is obvious. It could be reasoned that this model depicted valve conduct enough for some, useful outline purposes.

Amid the analyses intended to survey the general legitimacy of the model the suction valve worked without noteworthy stream limitation at blower channel, the delta channel and pipe work having been evacuated. Henceforth the zone of the suction "circles" in compares with the suction circle. (The lower shaded region) i.e. the suction plenum chamber weight did not differ fundamentally from the environmental weight P_i . Be that as it may, this basic circumstance couldn't be made tentatively for the release valve. I.e. a course of action couldn't be mode to keep up P_d consistent. The barrel weight (X), the plenum chamber weight (Y), and the weight distinction over the release valve ($Z = X - Y$) were each deliberate independently. Exact records were hard to acquire and a component of vulnerability was engaged with settling the datum for the trial follows. Thus it was not asserted that the exploratory records of weight distinction (Z) were adequately precise for important correlation with the logically anticipated weight contrast (Z)'. It was evident, notwithstanding, that the plenum chamber weight Y changed altogether and that the presumption in the diagnostic model that P_d stayed consistent was sketchy. By and by, the relationship amongst's hypothetical and exploratory outcomes for the two valves was thought to be adequate for some, outline purposes: for instance, to appraise the loss of volumetric effectiveness because of suction valve throttling, the power utilization due to the "in addition to stacking" by the valves, changes in valve affect speeds at seat and stop with modification of blower speed, weight proportion, valve lift, valve spring solidness and preloading.

OBJECTIVES AND METHODOLOGY

The target of this task work is to effectively build up a plan of a Multi Cylinder Dual Piston component for a Pneumatic Reciprocating Pump. The component is to be dependable, straightforward, financially savvy and for all intents and purposes plausible. The point of this pivoting instrument is changed over to the responding component to give strength to the item on the liquid, in order to empower included power,

speed in the liquid in contrast with the past plan territories. This framework is additionally expected to upgrade comfort as the side power felt taking a turn is nearly less in Reciprocating Pump.

The technique received to utilize standard and by and by utilized parts in plan instead of to outline all segments from ground up. The upside of this technique is that, you don't need to invest crazy sum and energy in testing the uprightness of each part as they have officially demonstrated their value in true applications.

1. It had a substantial reaction time; this was not appropriate for a moving toward yield at a rapid.
2. Wear and tear of cylinder and interfacing bar is too high to be palatably utilized as a part of a Pneumatic Reciprocating Pump.
3. The framework utilized high torque engines; this alongside controls could shoot up the cost of generation.

Because of these inconveniences, the center outline was dropped and a completely new plan was characterized. The Pneumatic Reciprocating Pump utilizes the same turning component setup. The product to be utilized as a part of configuration is Catia V5 and testing of configuration is Ansys.

3.1 Summary of capacities

Like any product it is persistently being created to incorporate new usefulness. The subtle elements underneath mean to layout the extent of abilities to give a review instead of giving particular points of interest on the individual usefulness of the item.

Catia Elements is a product application inside the CAD/CAID/CAM/CAE classification, alongside other comparative items at present available.

3.2 Engineering Design

Catia Elements offers a scope of apparatuses to empower the age of an entire advanced portrayal of the item being composed. Notwithstanding the general geometry devices there is additionally the capacity to produce geometry of other incorporated plan trains, for example, modern and standard work and finish wiring definitions. Apparatuses are likewise accessible to help synergistic advancement.

3.3 Analysis

Ansys Elements has various investigation apparatuses accessible and covers warm, static, dynamic and weariness FEA examination alongside different instruments all intended to help with the advancement of the item. These apparatuses incorporate human variables, fabricating resistance, form stream and plan improvement. The outline streamlining can be utilized at a geometry level to acquire the ideal plan measurements and in conjunction with the FEA examination.

WORKING MECHANISM OF MULTI ACTING DUAL RECIPROCATING PUMP

In the event that a responding pump utilizes one side of the cylinder for pumping fluid, at that point it is known as a Multi Acting Reciprocating Pump.

4.1 Main Parts of Multi Acting Reciprocating Pump

1. Chamber, Piston, Piston Rod, Connecting Rod and Crank

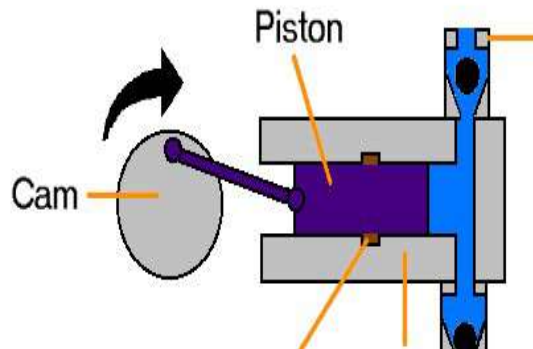

2. Suction Pipe and Suction Valve

3. Conveyance Pipe and Delivery Valve

4.2 Working Principle of Multi Acting Reciprocating Pump

In a Multi-activity responding pump, fluid follows up on one side of the cylinder as it were. A multi-acting responding pumps which has one suction pipe and one conveyance pipe; It is generally put over the fluid level in the sump.

Scotch Yoke Mechanism

The scotch burden system is responding movement component, changing over the liner movement of a slider into rotational movement, or the other way around. The cylinder or other responding part is specifically coupled to a sliding burden with a space that draws in a stick on the pivoting part. In numerous inside ignition motor, direct movement is changed over into rotational movement by methods for a crankshaft, a cylinder and a bar that interfaces them.

The scotch burden is thought to be a, more effective methods for delivering the rotational movement as it invests more energy at the high purpose of its revolution than a cylinder and it has less parts.

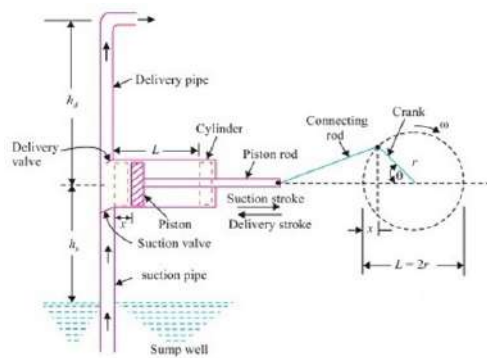

4.3 Comparing Simple Crank/Slider and Scotch Yoke Mechanisms

The basic wrench/slider and the Scotch burden (called the Donkey Crosshead in Great Britain) are two instruments for changing amongst rotational and straight movement. This Demonstration analyzes the sliding joint kinematics—the removals, speeds, and increasing velocities—delivered by the two components as elements of the basic information wrench point. The component schematic demonstrates the common wrench in dark, the interfacing pole of the basic wrench instrument in blue, and the Scotch burden superposed in red. The kinematics for the sliding joint are plotted for an entire cycle in relating hues on the strip diagram. To energize the Demonstration, tap on the "+" to one side of the "wrench edge" slider to open playback controls.

4.4 Selection of good Pump:

It relies upon the reason or the required activity.

On the off chance that the intention is high stream rates to separations and a considerable measure of spots like cooling pump in motors where high weight isn't required, at that point the outward pump will be great.

On the off chance that u need high weight or high capacity of beating the opposition like water lifting pump and fuel draw in motors, at that point the removal pump will be great.

- The outward has more stream rates than positive pumps.
- The positive pump has a larger number of weights at yield than radiating pump.

It absolutely relies on the reason and place at where the pump is to be utilized. I have seen the vast majority of the pump organizations like to utilize outward pumps because of its simple support and proficiency.

Liquid Discharge

Outward pump releases liquid persistently.

Responding pump releases liquid in beats.

4.5 The points of interest contrasted with a standard crankshaft and interfacing pole setup are:

- High torque yield with a little barrel estimate.
- Fewer moving parts.
- Smoother task.
- Higher level of the time spent at top flawlessly focused enhancing motor effectiveness.
- In a motor application, end of joint normally served by a wrist stick, and close end of cylinder skirt and barrel scraping, as side stacking of cylinder because of sine of interfacing pole point is dispensed with.

4.6 The detriments are:

- Rapid wear of the space in the burden caused by sliding rubbing and high contact weights.
- Lesser level of the time spent at base flawlessly focused diminishing blowdown time for two stroke motors.

- The state of the movement of the cylinder is an unadulterated sine wave after some time given a steady rotational speed.

CHAPTER – V

DESIGN METHODOLOGY OF AUTOMATIC MULTI ACTING DUAL CYLINDER PNEUMATIC RECIPROCATING PUMP

5.1 Introduction to CATIA

Modeling of Automatic Multi Acting Dual Cylinder Pneumatic Reciprocating Pump in CATIA V5

This Automatic Multi Acting Dual Cylinder Pneumatic Reciprocating Pump is composed utilizing CATIA V5 programming. This product utilized as a part of car, aviation, shopper merchandise, overwhelming designing and so forth it is ground-breaking programming for planning confounded 3d models, utilizations of CATIA Version 5 like part configuration, get together outline.

The same CATIA V5 R20 3d display and 2d drawing model is appeared beneath for reference. Measurements are taken from. The outline of 3d demonstrate is done in CATIA V5 programming, and after that to do test we are utilizing beneath specified software's.

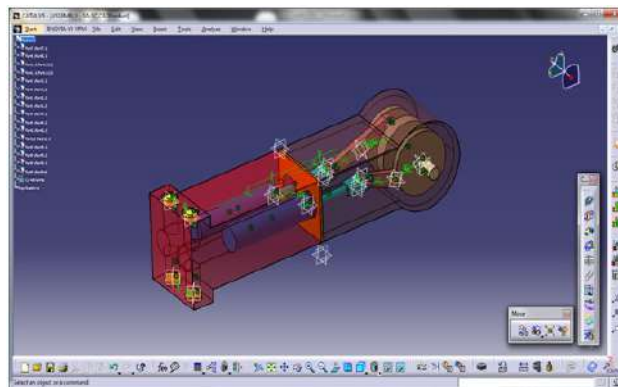

Fig: Model outline of Pneumatic Reciprocating Pump in CATIA-V5

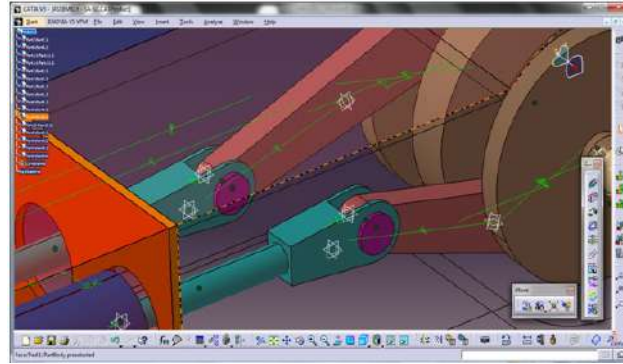

Fig: Model game plan of instrument in CATIA-V5

Assembly Modeling of Automatic Multi Acting Dual Cylinder Pneumatic Reciprocating Pump

Imperative - Coincidence:

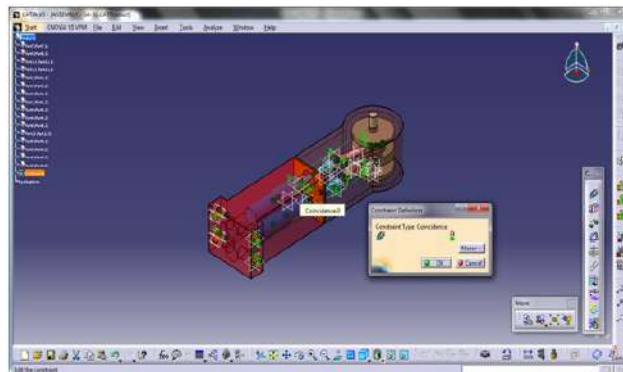

Fig: Constraint – Coincidence

Imperative - Offset:

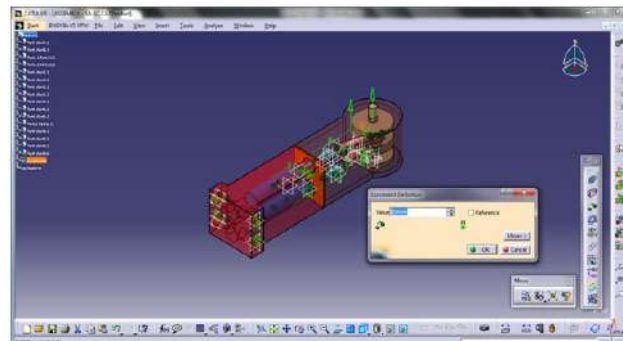

Fig: Constraint - Offset:

Control: This summon is utilized to control/turn/pivot the segment in any required bearing according to the need/reasonable limitations are to be connected on the segment.

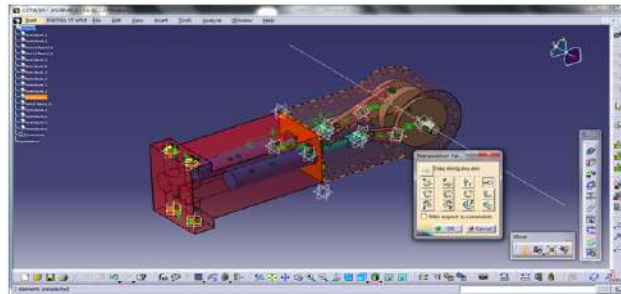

Fig: Using Manipulate Command

Multi View: This is the order in which every one of the perspectives of the part/model can be shown on the screen at a same time, they can be altered under the workbench.

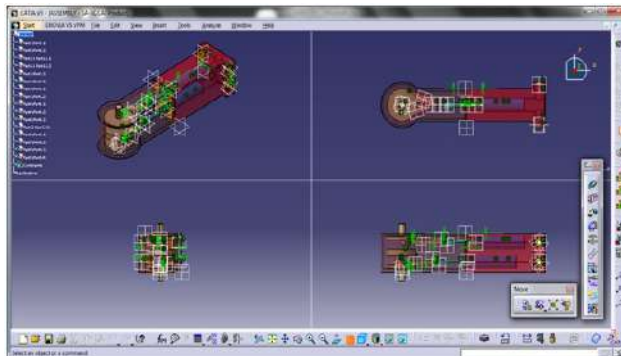

Fig: Using Multi View Command

ANALYSIS OF AUTOMATIC MULTI ACTING DUAL CYLINDER PNEUMATIC RECIPROCATING PUMP

6.1 Procedure for FE Analysis Using ANSYS:

The examination of the Automatic Multi Acting Dual Cylinder Pneumatic Reciprocating Pump are finished utilizing ANSYS. For contend get together isn't required, is to did by applying minutes at the revolution area along which hub we have to say. Settling area is base legs.

6.2 Preprocessor

In this stage the accompanying advances were executed:

- **Import record in ANSYS window**

Record Menu > Import > STEP > Click alright for the flew up discourse box > Click "Peruse" and pick the record spared from CATIAV5R20 > Click alright to import the document

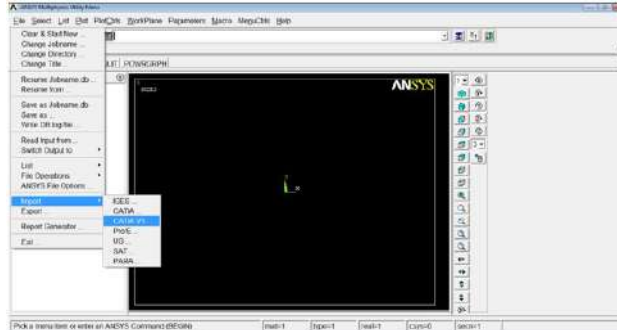

Fig. Import board in Ansys.

These parts are unraveled utilizing Analysis for checking the pressure, strains and removals while turning.

In the wake of finishing the cross section of every get together segments next is to do examination in view of the OEM (Original Equipment of Manufacturer) application. So every one of the models which are dissected, we have to specify in the Ansys programming to get precise outcomes according to the first segment. A portion of the parts are should have been understood utilizing static examination.

Load is connected and settling at the base key area, was approved in the examination. The material and geometric properties are recorded.

DISCUSSION ON ANALYSYS RESULT

7.1 Results of Displacement investigation:

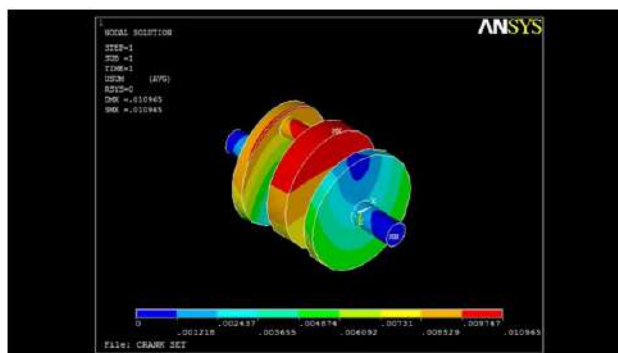

7.2 Results of Stress investigation:

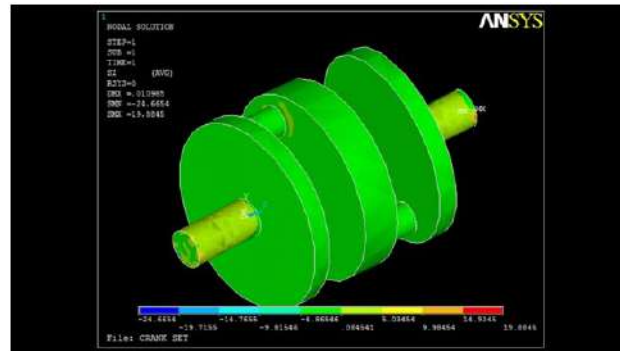

6.3 Results of Strain investigation:

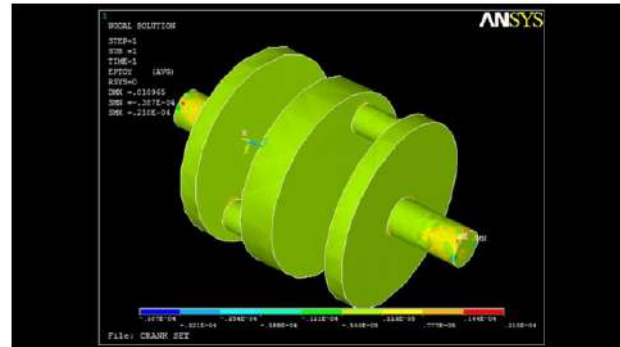

CONCLUSION

It can be seen from the above result that, our objective to increase the efficiency of fluid flow velocity of a single cylinder in a pneumatic reciprocating pump has been successful. As shown above figures the displacement of the complete design assembly is meshed and solved using Ansys and displacement is $0.889E-03\text{mm}$ which is very less. This is showing us that clearly each component in assembly is having minor displacement.

Stress is at the fixing location (Minimum Stress which is acceptable). The value is -16.268MPa which is very less compared to yield value of Mild steel; this is below the yield point.

The maximum stress is coming, this solution solving with the help of Ansys software so that the maximum stress is 1.312 MPa which is very less .so we can conclude our design parameters are approximately correct.

The design of the pneumatic pump and transferring of rotating to reciprocating mechanism worked flawlessly in analysis as well. Hence, higher percentage of the time spent at top dead center has improved the efficiency of the pump. All these facts point to the completion of our objective in high esteem.

REFERENCES

- Costagliola, M. "The Theory of Spring-Loaded valves for Reciprocating Pumps" J. Application. Mech., Dec. 1950, 17, 4, p.415. "Elements of a Reed Type Valve" D.Sc. Postulation, M.I. T., 1949
- Wombsganss, M. W. and Cohen, R. "Elements of a Reciprocating Pumps with Automatic Reed Valves" Proc. XII Int. Congr. Refrig ., Madri::l, 1967, paper no.3.06
- Calculation of suction and pressure forms in responding Pumps Khimisheskoe I Neftyonae Mashinostroenie nil, 1965, p.6.
- Up overlay, R. W., "A Study of Unsteady Flow in a Reciprocating Pumps " Ph.D. Proposition, University of New South Wales, 1967
- Traversari, A. and Lacitignola, P. "Utilize and Calculation of Ring Type Valves for Reciprocating Pumps", Ouanderni Pignone House Journal No. 16, Sept. 1970
- Maclaren. J. F. T. and Kerr, S. V. "Examination of Valve Behavior in Reciprocating Pumps" Proc. XII lp~ • Cong. Refrig., Madrid 1967, paper no. 3.39
- Tauber, S. and Blomsa, E.C. "Hypothetical and Experimental Investigation of Valve Movement and Inslotiomry Gas Flow in a Reciprocating Pumps" Proc. XlllInt. Cong. Refrig., Washington, 1971, tceper m.3.14
- Maclaren, J.F.T. and Kerr, S.V.! "An Analytical and Experimental Study of Self-acting Valves in a Reciprocating Air Pumps" I.Mech. E. Meeting, "Mechanical Reciprocating and Rotary Pumps Design and Operational Problems" paper no. 3, London, 1970
- The impact of spring attributes on plate valve task and Pumps execution). Archivum Budowy Maszyn VII n2, 1964, p.311
- Maclaren, J.F.T. and Kerr, S.V. Valves in Hermetic Pumps"!!!R Prague 1969, Annexe 1969-8 "Programmed Reed 1.1. R. Commission
- Rajamani R Vehicle Dynamics and control



- Ucer, A.S. "Insecure Flow in Reciprocating Pumps Systems" Ph.D. Theory, UMLST. 1970.
- Davis, H. "Impacts of Reciprocating Compressor Valve Design on Performance and Reliability" I.Mech. E. Meeting "Mechanical Reciprocating and Rotary Pumps Design and Operational Problems". Paper No. 2, London 1970
- Kerr, S. V. "Investigation of Auto Plastic Valves in Reciprocating Gas Pumps" Ph.D. Theory, University of Strathclyde, 1972